



Hydraulic industrial shock absorbers

Select the correct shock absorber and it will reduce shock vibration and noise. It will improve efficiency and extend machine life.

The function of shock absorber is to convert the kinetic energy of the moving object into heat and dissipate it into the atmosphere. It can stop a moving object smoothly and quietly before heavy impact occurs.

In order to save cost solid buffers such as polyurethane and rubber are often used. These cause noise and transient shock. The use of shock absorbers alleviates this resulting in both increased reliability and production. Additionally the noise reduction means they are environmentally friendly.

MDSC series: Non-adjustable shock absorbers.
Surface treatment: nickel plated: MDSC0806, MDSC1008, MDSC1210; others are black anodized.

MDFC series: Adjustable shock absorbers.

Operating principles of shock absorbers

Shock Absorber's main structure to combine with body, rod, bearing, inner tube, piston, fluid, spring. On impact the piston rod moves into the shock absorber and the hydraulic fluid is pushed into accumulator to produce resistant force, the pressure in the inner tube remains constant throughout the entire impact stroke. Shock Absorbers providing a linear deceleration and brings the impacting object to stop smoothly and quietly. At the end of the impact stroke, the return spring pushes the piston to its original position for next cycle

Order example

MDSC - 1415 - 1 - □ - M14 × 1.5

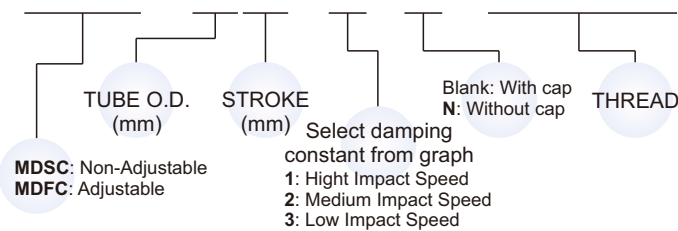

Comparison of shock absorbing of dash pots, PU rubbers, springs and shock absorbers

The springs and PU Rubbers are widespread to use in earlier period, but due to provide non-linear deceleration and to result in strong resistance, all the kinetic energy of moving objects is not absorption and produce counter pressure, this is in low efficiency.

If linear deceleration is necessary for a moving object. Mindman Shock Absorber is your best choice.

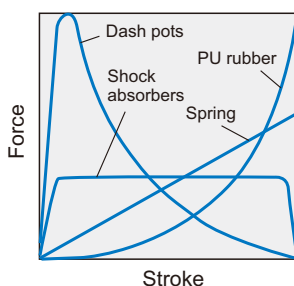

Main structures

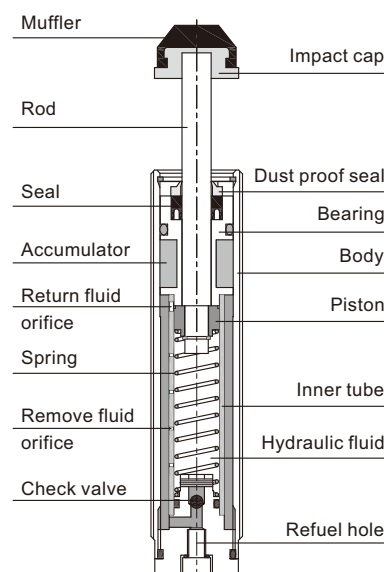

Specification

Order no.	Stroke (mm)	Max. Nm per cycle (Nm)	Effective max. weight (kg)	Max. impact speed (m/s)	Max. Nm per hour (Nm)	Operating temp. (°C)
MDSC-0806-1	6	1.8	0.9 ~ 5.6	2.0	2,400	-10~+70 (No freezing)
MDSC-0806-2	6	1.8	2.5 ~ 10	1.2	2,400	-10~+70 (No freezing)
MDSC-0806-3	6	1.8	5.6 ~ 22.5	0.8	2,400	-10~+70 (No freezing)
MDSC-1008-1	8	3.2	0.9 ~ 4.4	2.6	5,760	-10~+70 (No freezing)
MDSC-1008-2	8	3.2	2.8 ~ 10	1.5	5,760	-10~+70 (No freezing)
MDSC-1008-3	8	3.2	10 ~ 40	0.8	5,760	-10~+70 (No freezing)
MDSC-1210-1	10	6	1.8 ~ 12	2.6	10,800	-10~+70 (No freezing)
MDSC-1210-2	10	6	5.3 ~ 18.7	1.5	10,800	-10~+70 (No freezing)
MDSC-1210-3	10	6	12 ~ 75	0.8	10,800	-10~+70 (No freezing)
MDSC-1412-1	12	16	4.7 ~ 32	2.6	28,800	-10~+70 (No freezing)
MDSC-1412-2	12	16	14 ~ 50	1.5	28,800	-10~+70 (No freezing)
MDSC-1412-3	12	16	56 ~ 200	0.8	28,800	-10~+70 (No freezing)
MDSC-1415-1	15	20	5.9 ~ 27.8	2.6	36,000	-10~+70 (No freezing)
MDSC-1415-2	15	20	17.8 ~ 62.5	1.5	36,000	-10~+70 (No freezing)
MDSC-1415-3	15	20	62.5 ~ 250	0.8	36,000	-10~+70 (No freezing)
MDSC-1425-1	25	28	4.6 ~ 25	3.5	58,800	-10~+70 (No freezing)
MDSC-1425-2	25	28	14 ~ 87.5	2.0	58,800	-10~+70 (No freezing)
MDSC-1425-3	25	28	25 ~ 350	1.5	58,800	-10~+70 (No freezing)

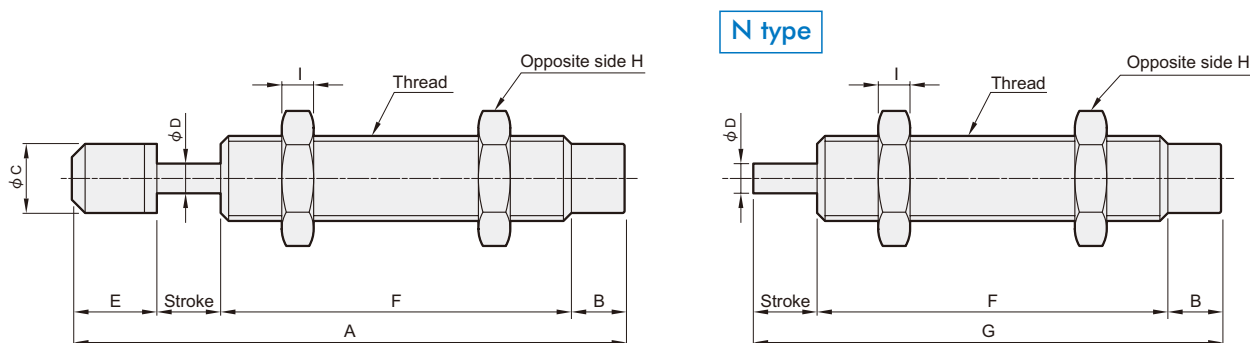

Dimensions

Order no.	Thread	Stroke (mm)	A	B	C	D	E	F	G	H	I	Weight (g)
MDSC-0806	M8×1.0	6	53	5	6.5	2.8	8.5	33.5	—	11	3	12
MDSC-0806-N	M8×1.0	6	—	5	—	2.8	—	33.5	44.5	11	3	11
MDSC-1008	M10×1.0	8	62	5	8.5	3	8.5	40.5	—	12.7	3	20
MDSC-1008-N	M10×1.0	8	—	5	—	3	—	40.5	53.5	12.7	3	19
MDSC-1210	M12×1.0	10	72	4.5	10.5	3	9.5	48	—	14	4	36
MDSC-1210-N	M12×1.0	10	—	4.5	—	3	—	48	62.5	14	4	34
MDSC-1412	M14×1.5	12	92.7	8	12.2	3.5	13.4	59.3	—	19	6	66
MDSC-1412-N	M14×1.5	12	—	8	—	3.5	—	59.3	79.3	19	6	63
MDSC-1415	M14×1.0 / 1.5	15	103.4	8	12.2	3.5	13.4	67	—	19	6	79
MDSC-1415-N	M14×1.0 / 1.5	15	—	8	—	3.5	—	67	90	19	6	76
MDSC-1425	M14×1.0 / 1.5	25	133.4	8	12.2	3.5	13.4	87	—	19	6	90
MDSC-1425-N	M14×1.0 / 1.5	25	—	8	—	3.5	—	87	120	19	6	86

Specification

Order no.	Stroke (mm)	Max. Nm per cycle (Nm)	Effective max. weight (kg)	Max. impact speed (m/s)	Max. Nm per hour (Nm)	Operating temp. (°C)
MDSC-2020-1	20	35	6.8 ~ 27	3.2	42,000	-10~+70 (No freezing)
MDSC-2020-2	20	35	17.5 ~ 70	2.0	42,000	-10~+70 (No freezing)
MDSC-2020-3	20	35	48.6 ~ 777	1.2	42,000	-10~+70 (No freezing)
MDSC-2030-1	30	46	9 ~ 36	3.2	55,200	-10~+70 (No freezing)
MDSC-2030-2	30	46	23 ~ 92	2.0	55,200	-10~+70 (No freezing)
MDSC-2030-3	30	46	64 ~ 575	1.2	55,200	-10~+70 (No freezing)
MDSC-2050-1	50	62	10.1 ~ 124	3.5	63,240	-10~+70 (No freezing)
MDSC-2050-2	50	62	18.3 ~ 253	2.6	63,240	-10~+70 (No freezing)
MDSC-2050-3	50	62	55 ~ 496	1.5	63,240	-10~+70 (No freezing)

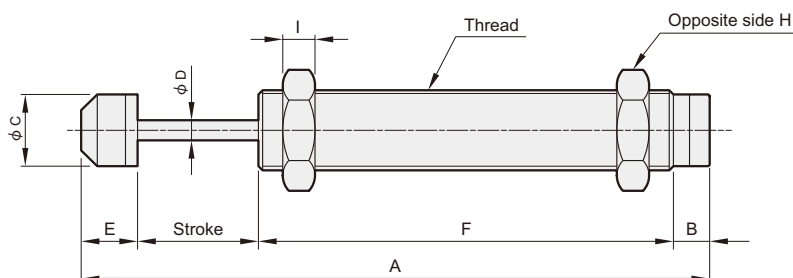

N type

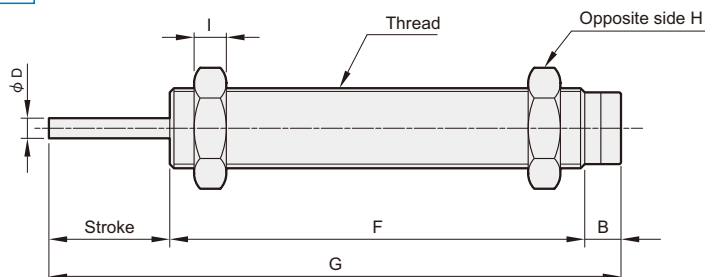

Dimensions

Order no.	Thread	Stroke (mm)	A	B	C	D	E	F	G	H	I	Weight (g)
MDSC-2020	M20×1.5	20	130	9	17.8	5	16	85	—	26	8	200
MDSC-2020-N	M20×1.5	20	—	9	—	5	—	85	114	26	8	196
MDSC-2030	M20×1.5	30	158	9	17.8	5	16	103	—	26	8	221
MDSC-2050	M20×1.5	50	222.5	9	17.8	5	16	147.5	—	26	8	293

Specification

Order no.	Stroke (mm)	Max. Nm per cycle (Nm)	Effective max. weight (kg)	Max. impact speed (m/s)	Max. Nm per hour (Nm)	Operating temp. (°C)
MDSC-2525-1	25	78	15 ~ 69	3.2	70,200	-10~+70 (No freezing)
MDSC-2525-2	25	78	39 ~ 433	2.0	70,200	-10~+70 (No freezing)
MDSC-2525-3	25	78	108 ~ 1733	1.2	70,200	-10~+70 (No freezing)
MDSC-2540-1	40	122	20 ~ 108	3.5	87,840	-10~+70 (No freezing)
MDSC-2540-2	40	122	50 ~ 381	2.2	87,840	-10~+70 (No freezing)
MDSC-2540-3	40	122	244 ~ 1991	1.0	87,840	-10~+70 (No freezing)
MDSC-2550-1	50	140	20 ~ 124	3.7	100,800	-10~+70 (No freezing)
MDSC-2550-2	50	140	48 ~ 438	2.4	100,800	-10~+70 (No freezing)
MDSC-2550-3	50	140	194 ~ 2286	1.2	100,800	-10~+70 (No freezing)
MDSC-2580-1	80	198	24.7 ~ 99	4	118,800	-10~+70 (No freezing)
MDSC-2580-2	80	198	44 ~ 396	3.0	118,800	-10~+70 (No freezing)
MDSC-2580-3	80	198	176 ~ 1584	1.5	118,800	-10~+70 (No freezing)
MDSC-2725-1	25	78	15 ~ 69	3.2	70,200	-10~+70 (No freezing)
MDSC-2725-2	25	78	39 ~ 433	2.0	70,200	-10~+70 (No freezing)
MDSC-2725-3	25	78	108 ~ 1733	1.2	70,200	-10~+70 (No freezing)
MDSC-3660-1	60	260	57 ~ 231	3.0	124,800	-10~+70 (No freezing)
MDSC-3660-2	60	260	130 ~ 813	2.0	124,800	-10~+70 (No freezing)
MDSC-3660-3	60	260	520 ~ 3250	1.0	124,800	-10~+70 (No freezing)

MDSC-2525
MDSC-2550
MDSC-2725

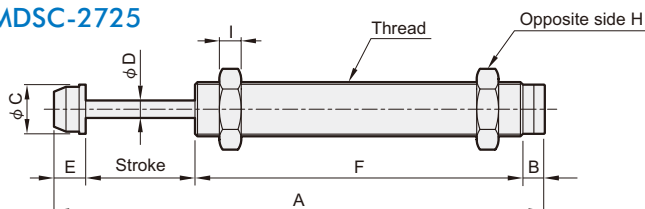

MDSC-2540
MDSC-3660

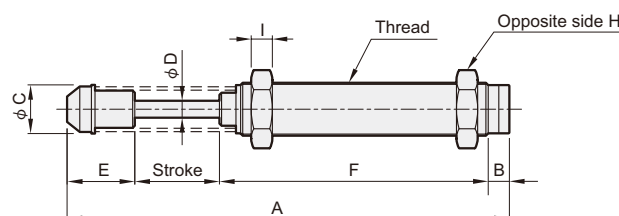

N type

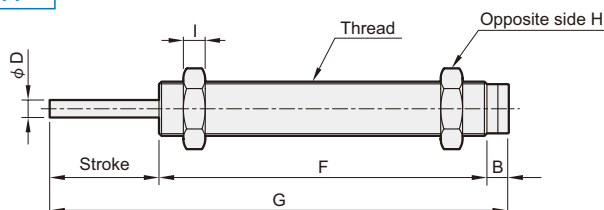

MDSC-2580

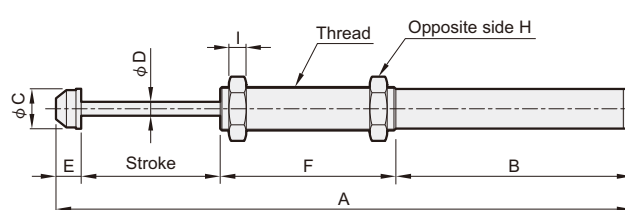

Dimensions

Order no.	Thread	Stroke (mm)	A	B	C	D	E	F	G	H	I	Weight (g)
MDSC-2525	M25 × 1.5 / 2.0	25	152.6	10	23	8	16.6	101	—	32	10	341
MDSC-2525-N	M25 × 1.5 / 2.0	25	—	10	—	8	—	101	136	32	10	336
MDSC-2540	M25 × 1.5 / 2.0	40	211	10	23	8	34	127	—	32	10	430
MDSC-2550	M25 × 1.5 / 2.0	50	226.6	10	23	8	16.6	150	—	32	10	430
MDSC-2580	M25 × 1.5 / 2.0	80	333.6	137	23	8	16.6	100	—	32	10	578
MDSC-2725	M27 × 3.0 / 1.5	25	152.6	10	23	8	14.5	101	—	32	10	335
MDSC-2725-N	M27 × 3.0 / 1.5	25	—	10	—	8	—	101	136	32	10	330
MDSC-3660	M36 × 1.5	60	247	11	36	10	22.5	153.5	—	46	15	1074

Specification

Order no.	Stroke (mm)	Max. Nm per cycle (Nm)	Effective max. weight (kg)	Max. impact speed (m/s)	Max. Nm per hour (Nm)	Operating temp. (°C)
MDFC-1410	10	15	2.9 ~ 120	3.2	27,000	-10~+70 (No freezing)
MDFC-2016	16	28	5.4 ~ 224	3.2	33,600	-10~+70 (No freezing)
MDFC-2020	20	35	6.8 ~ 280	3.2	42,000	-10~+70 (No freezing)
MDFC-2525	25	78	15 ~ 624	3.2	70,200	-10~+70 (No freezing)
MDFC-2550	50	140	27 ~ 1,120	3.2	100,800	-10~+70 (No freezing)
MDFC-2725	25	78	15 ~ 624	3.2	70,200	-10~+70 (No freezing)

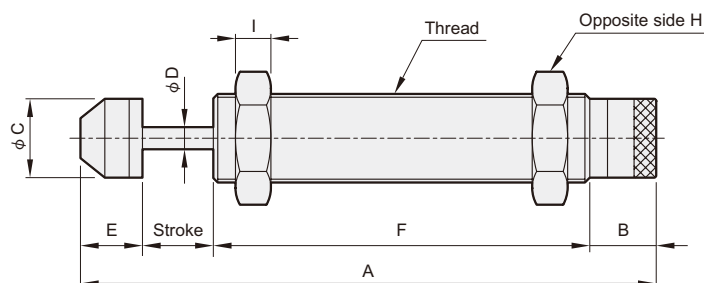

N type

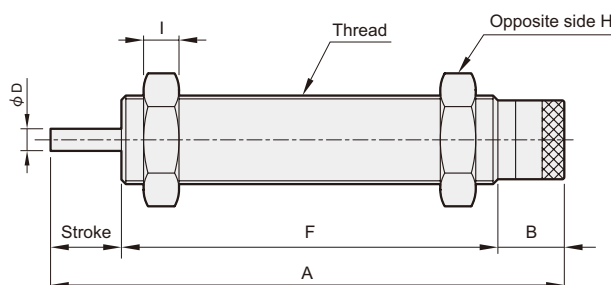

Dimensions

Order no.	Thread	Stroke (mm)	A	B	C	D	E	F	H	I	Weight (g)
MDFC-1410	M14×1.0 / 1.5	10	101.9	11.5	12.2	3.5	13.4	67	19	6	81
MDFC-1410-N	M14×1.0 / 1.5	10	88.5	11.5	—	3.5	—	67	19	6	78
MDFC-2016	M20×1.5	16	132	15	17.8	5	16	85	26	8	218
MDFC-2016-N	M20×1.5	16	116	15	—	5	—	85	26	8	214
MDFC-2020	M20×1.5	20	136	15	17.8	5	16	85	26	8	219
MDFC-2020-N	M20×1.5	20	120	15	—	5	—	85	26	8	215
MDFC-2525	M25×1.5 / 2.0	25	158.1	15.5	23	8	16.6	101	32	10	361
MDFC-2525-N	M25×1.5 / 2.0	25	141.5	15.5	—	8	—	101	32	10	356
MDFC-2550	M25×1.5 / 2.0	50	232.1	15.5	23	8	16.6	150	32	10	470
MDFC-2725	M27×1.5 / 3.0	25	158.1	15.5	23	8	16.6	101	32	6.5	355
MDFC-2725-N	M27×1.5 / 3.0	25	141.5	15.5	—	8	—	101	32	6.5	350

Specification

Order no.	Stroke (mm)	Max. Nm per cycle (Nm)	Effective max. weight (kg)	Max. impact speed (m/s)	Max. Nm per hour (Nm)	Operating temp. (°C)
MDFC-2540	40	122	23.8 ~ 976	3.2	87,840	-10~+70 (No freezing)
MDFC-3625	25	110	21 ~ 880	3.2	52,800	-10~+70 (No freezing)
MDFC-3650	50	220	43 ~ 1,760	3.2	105,600	-10~+70 (No freezing)

MDFC-2540

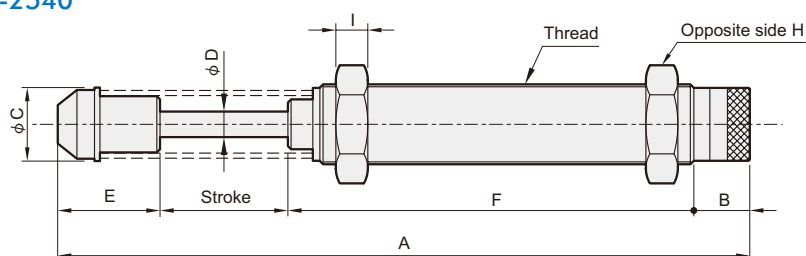

MDFC-3625 MDFC-3650

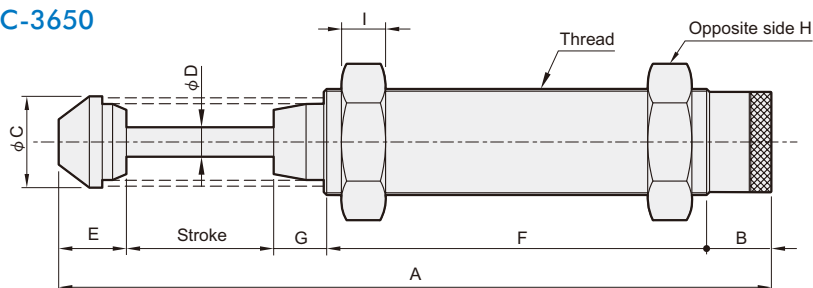

Dimensions

Order no.	Thread	Stroke (mm)	A	B	C	D	E	F	G	H	I	Weight (g)
MDFC-2540	M25×1.5 / 2.0	40	216.5	15.5	23	8	34	127	—	32	10	460
MDFC-3625	M36×1.5	25	186	18	36	10	22.5	106.5	14	46	15	974
MDFC-3650	M36×1.5	50	248	18	36	10	22.5	138	19.5	46	15	1144

Installation of stop collar and nut

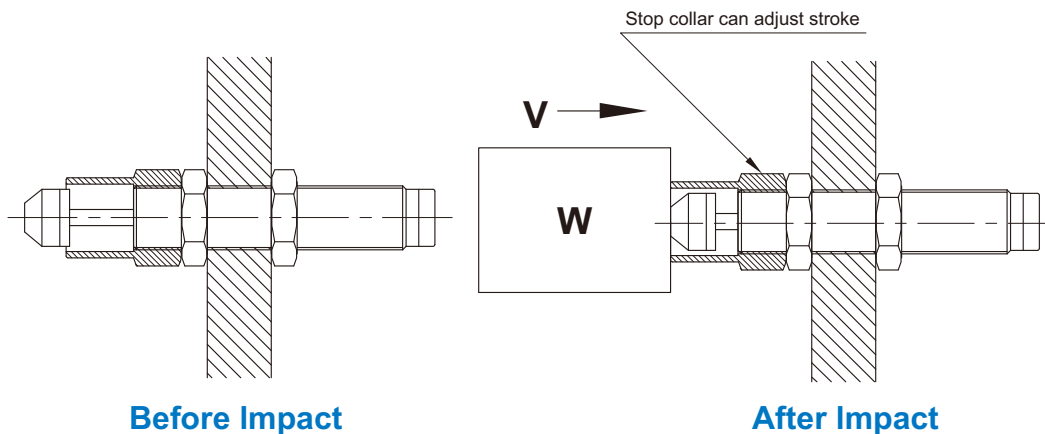

Accessories

<p>STC-08</p> <p>Match MDSC-0806</p>	<p>STC-20</p> <p>Match MDSC-2020 MDSC-2050 MDFC-2016 MDFC-2020</p>
<p>STC-10</p> <p>Match MDSC-1008</p>	<p>STC-25</p> <p>Match MDSC-2525 MDFC-2525</p>
<p>STC-12</p> <p>Match MDSC-1210</p>	<p>STC-25L</p> <p>Match MDSC-2540 MDSC-2550 MDSC-2580 MDFC-2540 MDFC-2550</p>
<p>STC-14</p> <p>Match MDSC-1412 MDSC-1415 MDFC-1410</p>	<p>STC-36</p> <p>Match MDSC-3660 MDFC-3625 MDFC-3650</p>

SHOCK ABSORBER

Four parameters are required to precisely determine the dimension of shock absorbers

- Mass to be decelerated m (kg)
- Impact velocity v (m/s)
- Propelling or driving force F (N)
- Number of impact cycles per hour C (/hr)

Some useful calculation formulas

- Kinetic energy: $E_k = mv^2/2$
- Drive energy: $E_d = F \cdot S$
- Free fall velocity: $v = \sqrt{2g \cdot h}$
- Pneumatic or hydraulic cylinder driving forces.
 $F = 0.00785 Pd^2$
- Maximum shock force (approximate).
 $F_m = 1.2 E_T/S$
- Propelling force generated by electric motors.
 $F = 3000 \text{ kW}/v$
- Total energy absorbed per hour.
 $E_{TC} = E_T \cdot C$

Symbols	Unit	Description
μ		Coefficient of friction
α	(rad)	Angle of incline
θ	(rad)	Side load angle
ω	(rad/s)	Angular velocity
A	(m)	Width
B	(m)	Thickness
C	(/hr)	Impact cycles per hour
d	(mm)	Cylinder bore diameter
E_d	(Nm)	Drive energy per cycle
E_k	(Nm)	Kinetic energy per cycle
E_T	(Nm)	Total energy per cycle
E_{TC}	(Nm)	Total energy per hour
F	(N)	Propelling force
F_m	(N)	Maximum shock force
g	(m/s ²)	Acceleration due to gravity (9.81 m/s)
h	(m)	Height
HM		Arresting torque factor for motors (normally 2.5)
kW	(kW)	Electric motor power
m	(kg)	Mass to be decelerated
M_e	(kg)	Effective mass
P	(bar)	Operation pressure
R	(m)	Radius
R_s	(m)	Shock absorber mounting distance from rotation center
S	(m)	Stroke
T	(Nm)	Driving torque
t	(s)	Deceleration time
v	(m/s)	Velocity of impact mass
v_s	(m/s)	Impact velocity at shock absorber

Example 1: Horizontal impact

Application data

$m = 300 \text{ kg}$
 $v = 1.0 \text{ m/s}$
 $S = 0.05 \text{ m}$
 $C = 300 \text{ /hr}$

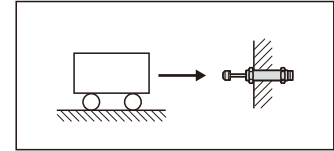

Formulas and calculation

$$E_k = \frac{mv^2}{2} = \frac{300 \cdot 1.0^2}{2} = 150 \text{ Nm}$$

$$E_T = E_k = 150 \text{ Nm}$$

$$E_{TC} = E_T \cdot C = 150 \cdot 300 = 45000 \text{ Nm/hr}$$

$$M_e = \frac{2E_T}{V^2} = \frac{2 \cdot 1.50}{1.0^2} = 300 \text{ kg}$$

Choose from sizing diagram: MDFC-3650 is adequate.

Example 2: Horizontal impact with propelling force

Application data

$m = 50 \text{ kg}$
 $v = 1.0 \text{ m/s}$
 $S = 0.04 \text{ m}$
 $F = 1000 \text{ N}$
 $C = 500 \text{ /hr}$

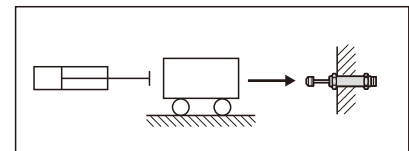

Formulas and calculation

$$E_k = \frac{mv^2}{2} = \frac{50 \cdot 1.0^2}{2} = 25 \text{ Nm}$$

$$E_d = F \cdot S = 1000 \cdot 0.04 = 40 \text{ Nm}$$

$$E_T = E_k + E_d = 25 + 40 = 65 \text{ Nm}$$

$$E_{TC} = E_T \cdot C = 65 \cdot 500 = 32500 \text{ Nm/hr}$$

$$M_e = \frac{2E_T}{V^2} = \frac{2 \cdot 65}{1.0^2} = 130 \text{ kg}$$

Choose from sizing diagram: MDFC-2540 is adequate.

Example 3: Free fall impact

Application data

$m = 30\text{kg}$
 $h = 0.5\text{m}$
 $S = 0.08\text{m}$
 $C = 300/\text{hr}$

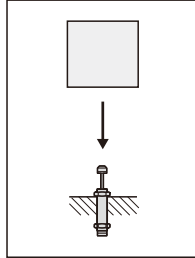

Formulas and calculation

$$v = \sqrt{2g \cdot h} = \sqrt{2 \cdot 9.81 \cdot 0.5} = 3.1 \text{ m/sec}$$

$$E_k = mg \cdot h = 30 \cdot 9.81 \cdot 0.5 = 147 \text{ Nm}$$

$$E_d = mg \cdot s = 30 \cdot 9.81 \cdot 0.08 = 23.5 \text{ Nm}$$

$$E_T = E_k + E_d = 147 + 23.5 = 170.5 \text{ Nm}$$

$$E_{TC} = E_T \cdot C = 170.5 \cdot 300 = 51150 \text{ Nm/hr}$$

$$M_e = \frac{2E_T}{V^2} = \frac{2 \cdot 170.5}{3.1^2} = 35.5 \text{ kg}$$

Choose from sizing diagram: MDSC-2580-1 is adequate.

Example 5: Horizontal impact with motor driving

Application data

$m = 50 \text{ kg}$
 $v = 1.5 \text{ m/s}$
 $kW = 2 \text{ kW}$
 $HM = 2.5$
 $S = 0.06 \text{ m}$
 $C = 100 / \text{hr}$

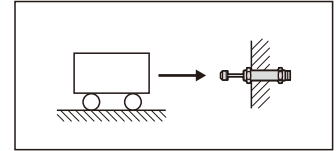

Formulas and calculation

$$E_k = \frac{mv^2}{2} = \frac{50 \cdot 1.5^2}{2} = 56.25 \text{ Nm}$$

$$E_d = F \cdot S = \frac{kW \cdot HM}{v} \cdot S = \frac{2000 \cdot 2.5}{1.5} \cdot 0.06 = 200 \text{ Nm}$$

$$E_T = E_k + E_d = 56.25 + 200 = 256.25 \text{ Nm}$$

$$E_{TC} = E_T \cdot C = 256.25 \cdot 100 = 25625 \text{ Nm/hr}$$

$$M_e = \frac{2E_T}{V^2} = \frac{2 \cdot 256.25}{1.5^2} = 227 \text{ kg}$$

Choose from sizing diagram: MDSC-3660-2 is adequate.

Example 4: Free fall impact with propelling

Application data

$m = 40 \text{ kg}$
 $h = 0.3 \text{ m}$
 $S = 0.025 \text{ m}$
 $P = 5 \text{ bar}$
 $d = 50 \text{ mm}$
 $C = 200 / \text{hr}$
 $v = 1.0 \text{ m/sec}$

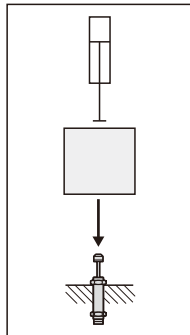

Formulas and calculation

$$E_k = \frac{mv^2}{2} = \frac{40 \cdot 1.0^2}{2} = 20 \text{ Nm}$$

$$E_d = F \cdot S = (mg + 0.0785Pd^2) \cdot S = (40 \cdot 9.81 + 0.0785 \cdot 5 \cdot 50^2) \cdot 0.025 = 34.3 \text{ Nm}$$

$$E_T = E_k + E_d = 20 + 34.3 = 54.3 \text{ Nm}$$

$$E_{TC} = E_T \cdot C = 54.3 \cdot 200 = 10860 \text{ Nm/hr}$$

$$M_e = \frac{2E_T}{V^2} = \frac{2 \cdot 54.3}{1.0^2} = 108.6 \text{ kg}$$

Choose from sizing diagram: MDSC-2525 is adequate.

Example 6: Inclined impact

Application data

$m = 30 \text{ kg}$
 $h = 0.25 \text{ m}$
 $S = 0.04 \text{ m}$
 $\alpha = 30^\circ$
 $C = 250 / \text{hr}$

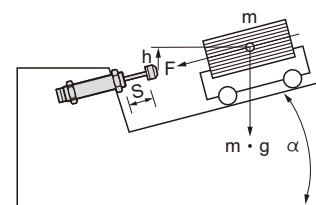

Formulas and calculation

$$v = \sqrt{2g \cdot h} = \sqrt{2 \cdot 9.81 \cdot 0.25} = 2.2 \text{ m/sec}$$

$$E_k = \frac{mv^2}{2} = \frac{30 \cdot 2.2^2}{2} = 72.6 \text{ Nm}$$

$$E_d = F \cdot S = m \cdot g \cdot S \cdot \sin \alpha = 30 \cdot 9.81 \cdot 0.04 \cdot \sin 30^\circ = 5.9 \text{ Nm}$$

$$E_T = E_k + E_d = 72.6 + 5.9 = 78.5 \text{ Nm}$$

$$E_{TC} = E_T \cdot C = 78.5 \cdot 250 = 19625 \text{ Nm/hr}$$

$$M_e = \frac{2E_T}{V^2} = \frac{2 \cdot 78.5}{2.2^2} = 32 \text{ kg}$$

Choose from sizing diagram: MDSC-2540-1 is adequate.

Example 7: Horizontal rotating door

Application data

$m = 20 \text{ kg}$
 $\omega = 2.0 \text{ rad/s}$
 $T = 20 \text{ Nm}$
 $R_s = 0.8 \text{ m}$
 $A = 1.0 \text{ m}$
 $B = 0.05 \text{ m}$
 $S = 0.016 \text{ m}$
 $C = 100 \text{ /hr}$

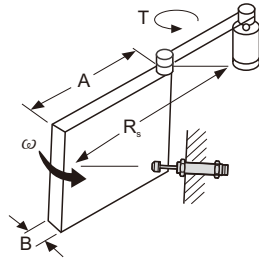

Formulas and calculation

$$I = \frac{m(4A^2+B^2)}{12} = \frac{20(4 \cdot 1.0^2+0.05^2)}{12} = 6.67 \text{ kg} \cdot \text{m}^2$$

$$E_k = \frac{I\omega^2}{2} = \frac{6.67 \cdot 2.0^2}{2} = 13.34 \text{ Nm}$$

$$\theta = \frac{s}{R_s} = \frac{0.04}{0.8} = 0.05 \text{ rad}$$

$$E_D = T \cdot \theta = 20 \cdot 0.05 = 1.0 \text{ Nm}$$

$$E_T = E_k + E_D = 13.34 + 1.0 = 14.34 \text{ Nm}$$

$$E_{TC} = E_T \cdot C = 14.34 \cdot 100 = 1434 \text{ Nm/hr}$$

$$v = \omega \cdot R_s = 2.0 \cdot 0.8 = 1.6 \text{ m/s}$$

$$M_e = \frac{2E_T}{V^2} = \frac{2 \cdot 14.34}{1.6^2} = 11.20 \text{ kg}$$

Choose from sizing diagram: MDFC-2016 is adequate.

Example 9: Horizontal mass on driven rollers

Application data

$m = 150 \text{ kg}$
 $v = 0.5 \text{ m/s}$
 $\mu = 0.25$
 $S = 0.02 \text{ m}$
 $C = 120 \text{ /hr}$

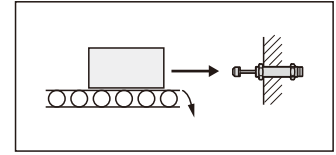

Formulas and calculation

$$E_k = \frac{mv^2}{2} = \frac{150 \cdot 0.5^2}{2} = 18.75 \text{ Nm}$$

$$E_D = F \cdot S = mg \mu \cdot S = 150 \cdot 9.81 \cdot 0.25 \cdot 0.02 = 7.35 \text{ Nm}$$

$$E_T = E_k + E_D = 18.73 + 7.35 = 26.1 \text{ Nm}$$

$$E_{TC} = E_T \cdot C = 26.1 \cdot 120 = 3132 \text{ Nm/hr}$$

$$M_e = \frac{2E_T}{V^2} = \frac{2 \cdot 26.1}{0.5^2} = 208.8 \text{ kg}$$

Choose from sizing diagram: MDSC-2020-3 is adequate.

Example 8: Rotary index table with propelling force

Application data

$m = 200 \text{ kg}$
 $\omega = 1.0 \text{ rad/s}$
 $T = 100 \text{ Nm}$
 $R = 0.5 \text{ m}$
 $R_s = 0.4 \text{ m}$
 $S = 0.04 \text{ m}$
 $C = 100 \text{ /hr}$

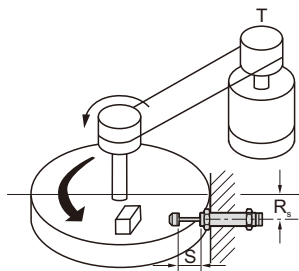

Formulas and calculation

$$I = \frac{mR^2}{2} = \frac{200 \cdot 0.5^2}{2} = 25 \text{ kg} \cdot \text{m}^2$$

$$E_k = \frac{I\omega^2}{2} = \frac{25 \cdot 1.0^2}{2} = 12.5 \text{ Nm}$$

$$\theta = \frac{s}{R_s} = \frac{0.04}{0.4} = 0.1 \text{ rad}$$

$$E_D = T \cdot \theta = 100 \cdot 0.1 = 10 \text{ Nm}$$

$$E_T = E_k + E_D = 12.5 + 10 = 22.5 \text{ Nm}$$

$$E_{TC} = E_T \cdot C = 22.5 \cdot 50 = 1125 \text{ Nm/hr}$$

$$v = \omega \cdot R_s = 1.0 \cdot 0.4 = 0.4 \text{ m/s}$$

$$M_e = \frac{2E_T}{V^2} = \frac{2 \cdot 22.5}{0.4^2} = 281 \text{ kg}$$

Choose from sizing diagram: MDFC-2540 is adequate.

Example 10: Rotating beam with driving force

Application data

$m = 40 \text{ kg}$
 $A = 0.5 \text{ m}$
 $B = 0.05 \text{ m}$
 $\omega = 2.0 \text{ rad/s}$
 $T = 10 \text{ Nm}$
 $R_s = 0.4 \text{ m}$
 $S = 0.05 \text{ m}$
 $C = 50 \text{ /hr}$

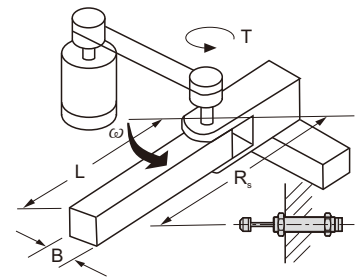

Formulas and calculation

$$I = \frac{m(4A^2+B^2)}{12} = \frac{40(4 \cdot 0.5^2+0.05^2)}{12} = 3.34 \text{ kg} \cdot \text{m}^2$$

$$E_k = \frac{I\omega^2}{2} = \frac{3.34 \cdot 2.0^2}{2} = 6.7 \text{ Nm}$$

$$\theta = \frac{s}{R_s} = \frac{0.05}{0.4} = 0.125 \text{ rad}$$

$$E_D = T \cdot \theta = 10 \cdot 0.125 = 1.25 \text{ Nm}$$

$$E_T = E_k + E_D = 6.7 + 1.25 = 8 \text{ Nm}$$

$$E_{TC} = E_T \cdot C = 8 \cdot 50 = 400 \text{ Nm/hr}$$

$$v = \omega \cdot R_s = 2.0 \cdot 0.4 = 0.8 \text{ m/s}$$

$$M_e = \frac{2E_T}{V^2} = \frac{2 \cdot 8}{0.8^2} = 25 \text{ kg}$$

Choose from sizing diagram: MDFC-2050 is adequate.